

GEA Grasso V Series

Piston compressors
for industrial refrigeration



Cooling and freezing evolved from excellence

Leading technology and experience, all in touch with your markets and processes

GEA is one of the leading manufacturers of piston and screw compressors and packages for industrial refrigeration. The extensive range of high-quality, reliable and modern refrigeration compressors can be applied in almost every industrial refrigeration process. Our products find their way to the end-user via contractors, distributors and Original Equipment Manufacturers (OEM). Our main markets for industrial refrigeration solutions are:

- Food processing
- Storage and distribution
- Industrial processes
- Sport and leisure

From the beginning, GEA refrigeration solutions have continuously been extended to cover many different industries. For most industrial cooling and freezing applications our products offer optimal solutions with high reliability and low energy consumption.

Refrigeration technology is an inherent and essential part of the food processing industry. GEA supplies an excellent range of components which can be used throughout the whole value chain, beginning with the production itself and ending with the product ready for market. GEA refrigeration solutions comprise components for cold storage on fishing vessels, cooling and freezing solutions for meat, vegetables, beer and beverages – within the production process or for storage. For storage and distribution of food along the trade chain, cooling and freezing is a must.

Refrigeration from GEA is also responsible for entertainment and well-being in leisure time. Winter sports like skating and skiing in a perfect, cool winter atmosphere – independent of season or geographical region – are the result of the application of GEA components. GEA refrigeration solutions allow our customers to focus 100 % on their business.

GEA provides cooling and freezing technology tailored to the requirements and wishes of our customers: cost-efficient, long-life, energy-efficient, sustainable and customized. After all, we know your business and your refrigeration needs from experience of more than 100 years. This is why we offer the best solutions together with top quality products. Solutions for your processes, for greater efficiency and for enhanced climate protection.

Reduce your Total Cost of Ownership

The new GEA Grasso V series piston compressors achieve the highest possible reliability

Trendsetter

With the new GEA Grasso V series piston compressors, GEA heralds the start of a complete new era for the industrial refrigeration market. GEA continues to invest in piston technology with a clear vision for the future, and with good reason. The Total Cost of Ownership, where energy is the major part, has become an important issue, which is why the market is now demanding energy-efficient solutions.

Innovation

During the development of the GEA Grasso V series, GEA continually put itself in the position of the end-user. Time and again, each component was assessed for the most important elements that contribute to a low Total Cost of Ownership:

- Energy efficiency
- Minimal maintenance costs
- Maximum reliability with minimal downtime

Besides having satisfied end users in terms of lower running costs and very long service life, contractors also benefit from this new development in terms of

ease of installation and on-time maintenance. GEA's worldwide professional product support is a known fact inside the world of industrial refrigeration.

Sustainability

To get the maximum out of the GEA Grasso V series compressor design, we focus on natural refrigerants like NH_3 . Our customers can be sure that environmentally friendly NH_3 is not subject to the global warming and ozone layer discussions. And when it comes down to efficiency, ammonia is definitely number one.

The new GEA Grasso V series is a 100% European quality product. More than 100 years of design experience have been combined with state-of-the-art research and technology. The result is not only the most efficient and reliable piston compressor on the market but also a compressor with extended and flexible service intervals compared to previous standards. As a consequence of this intensive design the GEA Grasso V series achieves the highest possible reliability. With the V series, GEA sets a new standard for the future.

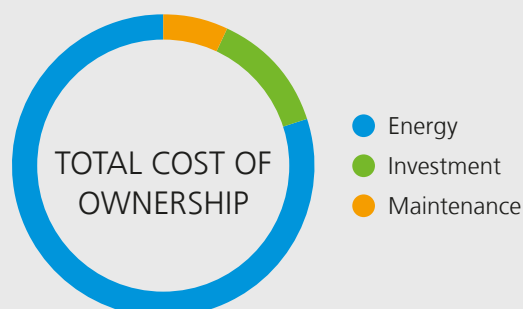



Revolutionary design and performance

The end-users' choice for well-designed, cost-effective refrigeration

Energy

Piston compressor technology is synonymous with highly efficient operation resulting in lower power consumption. This is the result of minimum internal leakages, automatic head pressure adjustment and increased efficiency at lower speed especially in combination with a frequency inverter. This new design contributes to a further reduction of power consumption under all circumstances.

Minimum maintenance

The selection of the highest quality parts and construction methods enables GEA to reduce the downtime and maintenance frequency for this machine significantly when compared to the traditional compressor maintenance guidelines! Furthermore we believe that maintenance should only be carried out when it is necessary, this is in contradiction with the fixed maintenance schedules in general use today for refrigeration compressors. That is why each GEA Grasso V compressor is factory-fitted with a so-called 'conditional maintenance monitor', which indicates the right time for maintenance.

Unconditional reliability

GEA believes its customers should be able to focus 100% on their business. That is why we place so much emphasis on reliable and trustworthy systems. With the maintenance carried out in accordance with the maintenance intervals indicated by the GEA Maintenance Monitor, you can be sure of problem-free operation throughout the entire lifespan of the machine so you can concentrate on your business.

Lower investment

The optimized components of this new compressor series as well as the chosen running speed result in a lower price per kW

cooling power. Due to the very low oil carry-over of the complete range of the GEA Grasso V series, packaging of these compressors without oil separator is an option.

An unequalled design

The design of the welded compressor crankcase housing is innovative 'from top to bottom'. This is probably the most striking change in the history of GEA welded compressor construction. By using a revolutionary process of forming the steel sections creating the complete crankcase, the optimum shape and size can be made without compromise and it retains all the advantages of a welded concept.

An unequalled performance

The optimized shape and size of the compressor crankcase made it possible to achieve the highest energy efficiency, minimum maintenance and maximum reliability. Another result is a much lower sound level. The unique combination of a welded crankcase with integrated, generously sized suction chamber and cast iron, externally positioned, cylinder heads creates an even better internal temperature separation between the suction side and the discharge side of the compressor, compared with existing models. In practice this results in less internal superheat, more stable oil temperature and, as a consequence, a higher volumetric efficiency. Another effect is that the field of application for part load running has been extended.

An unequalled reduction of costs

The running cost or TCO (Total Cost of Ownership) becomes more and more an important factor in designing the total refrigerating system. Since the major costs are located in the engine room area, the impact of a well-designed, cost-effective, refrigeration compressor is huge.

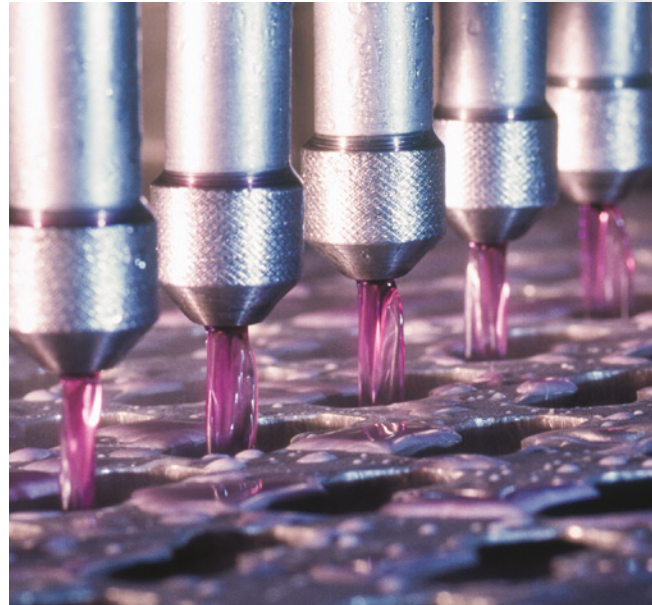

REDUCED COSTS COMPARED TO EXISTING MODELS

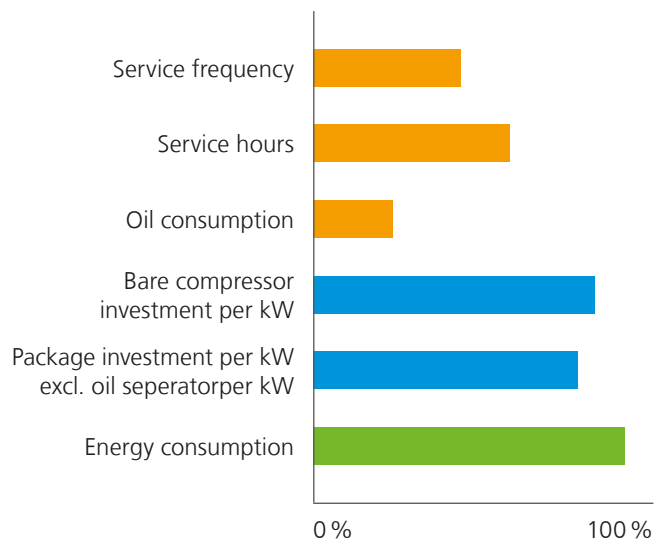

Total Cost of Ownership savings up to 12 %

Eleven key features

The revolutionary design of the steel-welded compressor housing in combination with the temperature-isolated cylinder heads has a maximum contribution to the thermodynamic advantages of the new GEA Grasso V series. Together with the best proven parts this results in the most efficient GEA industrial piston compressor GEA has ever made.

1. Safety first

- Counter pressure independent overflow valve(s) between suction and discharge chamber to secure a safe operation.

2. Optimized suction gas entry

- Oversized suction gas chamber and optimized filtering and distribution results in low pressure drop and increased resistance against liquid hammer.

3. Flexible and extended maintenance

- To calculate and indicate upcoming maintenance intervals by means of measuring of actual running conditions.

4. Optimized temperature separation

- The cold suction chamber is clearly separated from the hot discharge area by means of an isolating gasket and an air gap. In this way we have less internal heating up the suction gas resulting in lower discharge temperatures and more flexibility in part load operation.

5. Oil pump

- Different sizes tuned to compressor model.

6. Oil filter

- Large capacity 'screw-on' oil filter to cover long service intervals. Externally accessible.

7. Maximum lifetime

- Composite material for suction and discharge valves.
- Free-flow discharge valve configuration with gas damping chambers.
- High volume and low gas velocity suction chamber.
- Oil pump size adapted to compressor size.

8. Reliability and ease of maintenance

- Axial roller bearing construction to withstand high crankcase pressures for maximum lifetime at high loads.
- Increased main bearing diameter for stable low-speed inverter drive running.
- Large-capacity, externally mounted oil filter for long service intervals.
- Full oil pump flow over shaft seal for maximum cooling/life time extension.

9. O-ring sealing for maximum tightness

- Easy disassembly and assembly.
- Over 60 % fewer fixing bolts contribute to reduced service times.

10. Minimized oil carry-over to refrigeration system

- The oversized common suction chamber, the position of the cylinder liners, as well as the increased distance between oil sump and crankshaft (and lower internal temperatures).

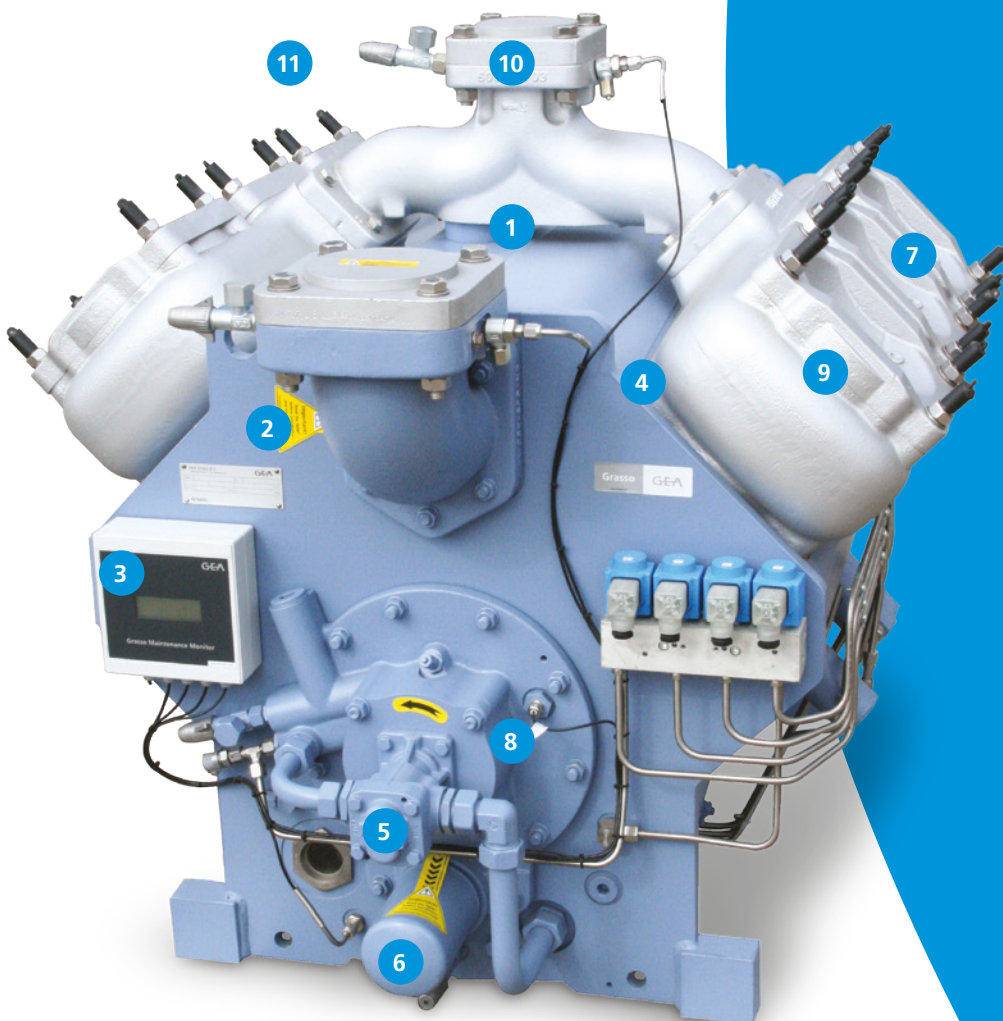

result in an extremely low oil carry-over. The necessity of using an oil separator is subject to application and, in some cases, can be omitted.

11. Low noise level

- Modular setup of the steel-welded housing in combination with the rigid cast iron cylinder heads guarantees the lowest possible noise emission.

A complete product range

Find the right compressor for each application in the well-balanced GEA Grasso V family. For this, the capacity steps between models have been set as narrow as possible, increasing in steps of two cylinders. Two different bore and stroke ratios are integrated into the basic design to cover the required swept volume range without capacity overlap.

Single-stage

The single-stage series, having 7 models, starts with a 4-cylinder, small bore x stroke for accurate capacity control and ends with a 10-cylinder big bore x stroke to cover a swept volume of 1,592 m³/h. The modular construction and the intermediate plate for the larger compressors guarantee a smooth vibration-free running and low noise emission.

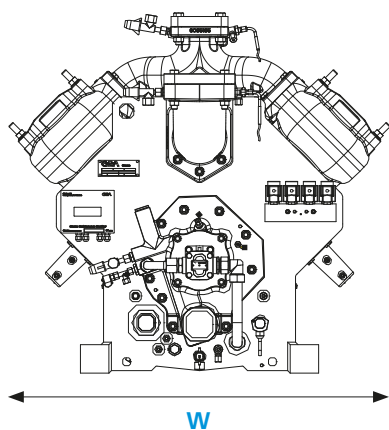

Two-stage

Two-stage-or 'compound' models benefit from the same characteristics as the single-stage models. Internally they have separate suction chambers for low and intermediate pressure and, on the outside, 2 connections are added for the intermediate side. The range also comprises 7 models, each with only one LP/HP cylinder ratio in order to simplify the selection procedure. For the two-stage compressors several highly efficient and patented intermediate cooling systems are available.

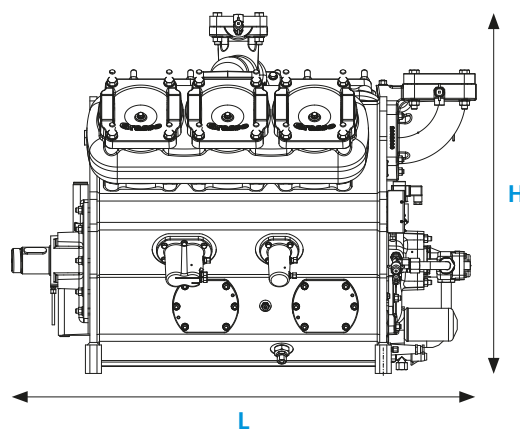

SINGLE-STAGE COMPRESSORS

Models	Swept volume* (m ³ /h)	Number of cylinders	Speed min ⁻¹	Cooling cap. (kW)**		Dimensions (mm)			Weight (kg)
				NH ₃		L	W	H	
				-10/+35°C	0/+40°C				
GEA Grasso V 300	290	4	1,500	155	237	882	933	922	575
GEA Grasso V 450	435	6	1,500	233	355	1,076	933	922	751
GEA Grasso V 600	580	8	1,500	310	474	1,363	933	922	1,042
GEA Grasso V 700	637	4	1,200	367	549	1,062	1,076	1,013	794
GEA Grasso V 1100	955	6	1,200	550	823	1,306	1,076	1,013	1,054
GEA Grasso V 1400	1,274	8	1,200	734	1,098	1,666	1,076	1,027	1,495
GEA Grasso V 1800	1,592	10	1,200	917	1,372	1,909	1,076	1,027	1,725

TWO-STAGE COMPRESSORS

Models	Swept volume* (m ³ /h)	Number of cylinders low/high- stage	Speed min ⁻¹	Cooling cap. (kW)**		Dimensions (mm)			Weight (kg)
				NH ₃ ***		L	W	H	
				-35/+35°C	-40/+35°C				
GEA Grasso V 300T	217	3/1	1,500	45	34	935	940	922	590
GEA Grasso V 450T	290	4/2	1,500	67	52	1,310	940	922	769
GEA Grasso V 600T	435	6/2	1,500	90	68	1,425	940	922	1,062
GEA Grasso V 700T	478	3/1	1,200	108	85	1,060	1,072	1,013	814
GEA Grasso V 1100T	637	4/2	1,200	157	123	1,304	1,072	1,013	1,077
GEA Grasso V 1400T	955	6/2	1,200	217	170	1,672	1,072	1,027	1,520
GEA Grasso V 1800T	1,114	7/3	1,200	262	203	1,874	1,072	1,027	1,755

* Theoretical swept volume based on low stage cylinders

** Based on: 0 K subcooling, 2 K superheat (non-useful)

*** Cooling capacity based on open flash interstage cooler system

Packaged compressors

At least 60 % of all compressors produced at GEA are turned into packages before they leave the factory.

The choice of components to fit on and around the compressors is huge, and the fact that all required components are factory-fitted gives the contractor the advantage to concentrate 100 % on the erection of the refrigeration plant.

Direct drive or V belt drive arrangements are available for all compressors. The introduction of high power inverters in combination with maintenance-free couplings gives the customer the opportunity to positively influence energy and maintenance costs.

The extremely low oil carry-over, related to the design of the compressor particularly on cooling applications, is even less than 10 ppm and gives the customer the opportunity to execute a compressor package with or without an oil separator, depending on the system demands. The use of GEA's high-efficiency oil separator will further reduce the carry-over to an absolute minimum, and oil contamination through to the installation.

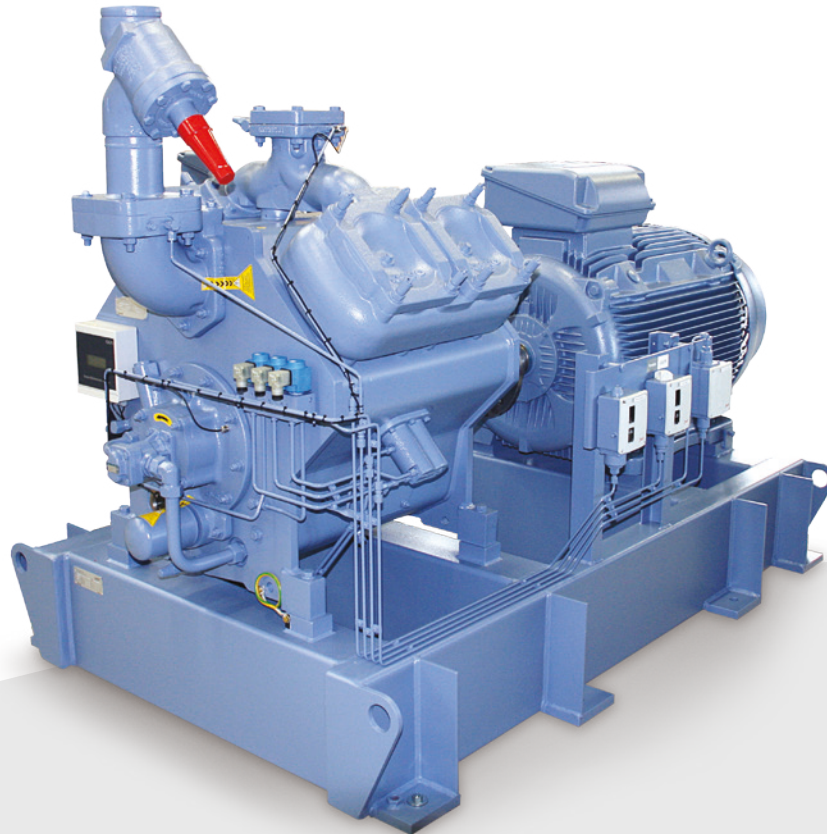



Good to know

We are proud of the quality and reliability of all GEA refrigeration solutions. Ingenious monitoring and service modules ensure optimum lifetime performance for you.

GEA Maintenance Monitor

The GEA Grasso V series compressor is equipped with the GEA Maintenance Monitor (GMM) This compact, microprocessor-based stand-alone unit monitors online the relevant data to determine the 'on-time' maintenance intervals. The monitor automatically generates a message for an upcoming A, B or C level service. This message can be read directly from a small built-in display, remote PC, or can be sent by email to the person/company responsible for the maintenance. When connected to a network, even real-time data are available as well as information about any upcoming service.

'On-time' maintenance balances the lifetime of wearing components and the expected reliability. In other words: The end user benefits from longer service intervals without jeopardizing reliability. In industrial refrigeration this is quite a new approach. The traditional 'fixed' service intervals will slowly be taken over by the new system. Therefore GEA is happy to present this monitoring system to the market. We are convinced that this, together with the GEA Grasso V series compressors, contributes to the reduction of the Total Cost of Ownership.

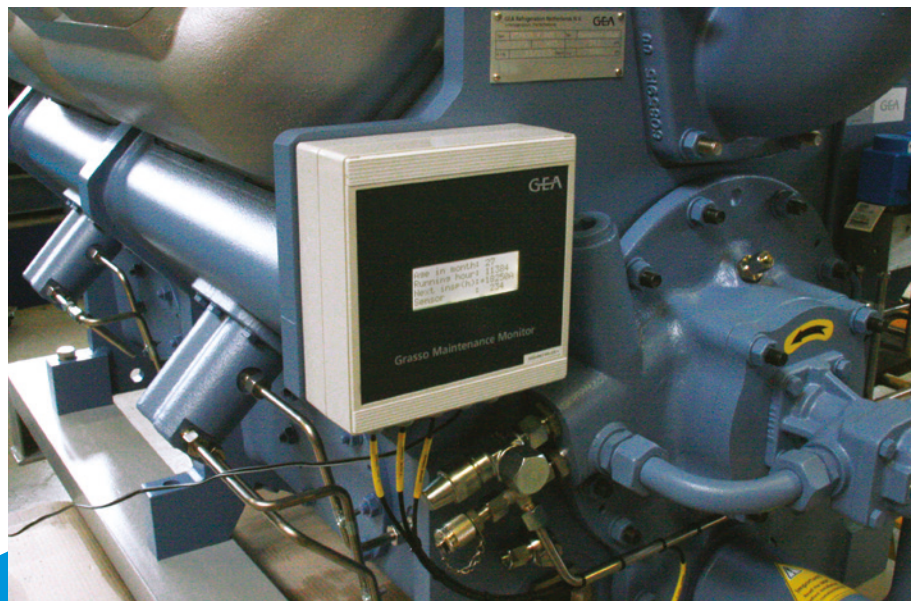

GEA Service

Our objective is to ensure that GEA piston compressors are well-designed and properly installed and maintained. We know that correct preventive maintenance will ensure the highest level of reliability and unexpected breakdowns can be minimized. At the same time the lifetime of compressors will increase.

With this in mind GEA takes care of its customers by offering the best possible service in terms of technical consultation, warranty management, field service and training courses. All supported by rapid spare parts supply all over the world.

Spare parts

A practical and fast-working spare parts organization has been established to supply the required spare parts worldwide. To shorten delivery times further, distribution centers have been created at GEA offices throughout the world. We have an extensive stock of spare parts, covering new as well as phased-out GEA compressors.

Laboratory tests and field experience have proven that the use of genuine GEA parts keeps compressor performance, reliability and a low Total Cost of Ownership at the optimum level.

GEA has created distribution centers at the GEA offices worldwide to be able to supply you directly and fast with the right parts. That is why the genuine GEA parts are the obvious choice.

Training courses

For GEA it is very important to ensure maximum support for the end-users all over the world. This can only be achieved when the right training programs are available. Local representatives and contractors are able to attend these training courses. These courses, tuned for design and service engineers, are focused on the correct selection and application of GEA compressors as well as performing the correct service to maintain the highest level of reliability.

These courses take place at the GEA manufacturing site for piston compressors. However, we can, on request, also perform this service locally if this is more convenient for a larger audience. We strongly recommend attending our training courses on a regular basis to offer the local market the best possible up-to-date support.





We live our values.

Excellence • Passion • Integrity • Responsibility • GEA-versity

GEA Group is a global engineering company with multi-billion euro sales and operations in more than 50 countries. Founded in 1881, the company is one of the largest providers of innovative equipment and process technology. GEA Group is listed in the STOXX® Europe 600 Index.

GEA Netherlands

GEA Refrigeration Netherlands N.V.

Parallelweg 25

5223 AL 's-Hertogenbosch,

The Netherlands

Phone: +31 (0)73 6203 911

refrigeration@gea.com

gea.com